

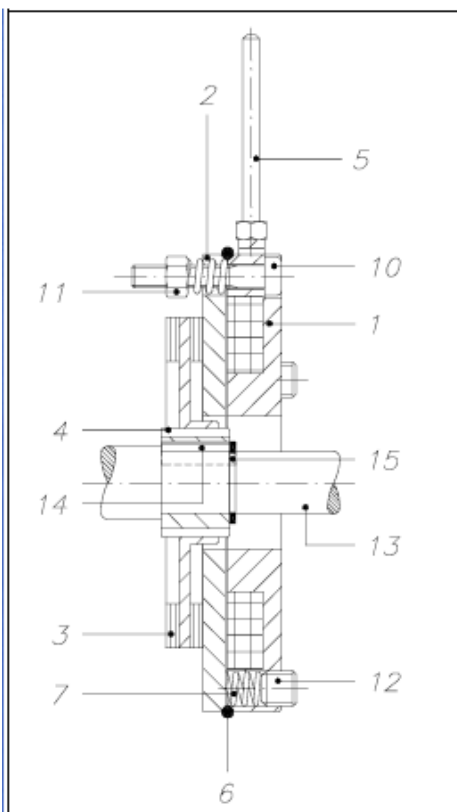

O.E.G. SPRING PRESSURE SAFETY BRAKES IN DIRECT CURRENT PCC TYPE

INSTALLATION AND MAINTENANCE MANUAL

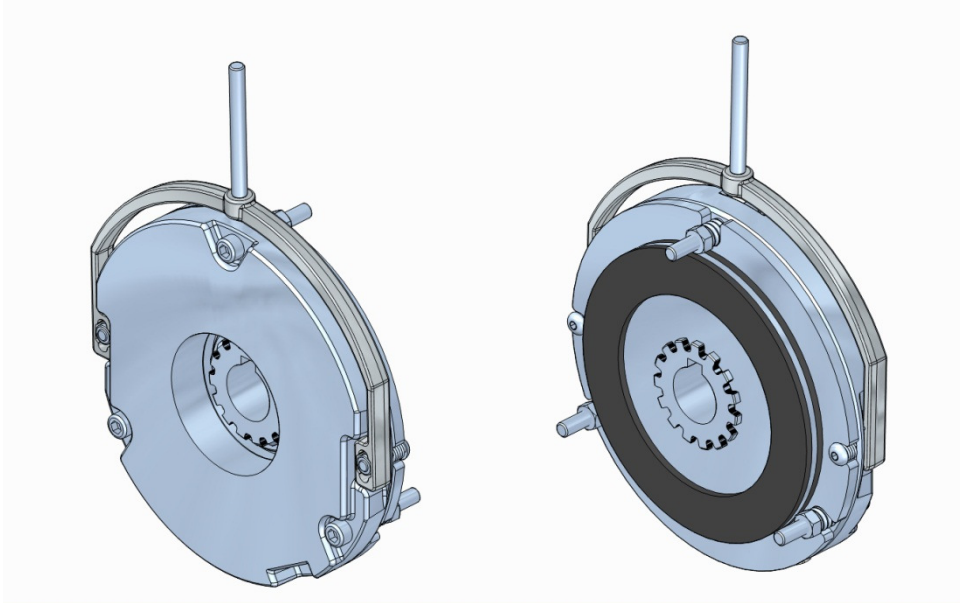

- | | |
|----|-------------------------|
| 1 | Magnet casing |
| 2 | Mobile anchor |
| 3 | Brake disc |
| 4 | Driving hub |
| 5 | Hand release (OPTIONAL) |
| 6 | Protection + "O" ring |
| 7 | Thrust spring |
| 10 | Fastening screw |
| 11 | Locking nut |
| 12 | Adjusting screw |
| 13 | Driving shaft |
| 14 | Key |
| 15 | Seeger ring |



INSTALLATION

- ⇒ Make sure the flange receiving the brake is flat and orthogonal with respect to the driving shaft.
- ⇒ Assemble the brake on the motor flange by means of the fastening screws.
- ⇒ Montare il freno sulla flangia motore mediante le viti di fissaggio.
- ⇒ Make sure the shaft projection has the dimensions and tolerances specified in the drawings.
- ⇒ Assemble the centre spring on the shaft.
- ⇒ Assemble the braking fan on the shaft fitted with the UNI 6604 tongue, shape B. Tighten the dowel into the hole on the driving shaft and lock it with anaerobic sealant. Assemble the washer and the self-locking nut. Adjust the air-gap to the value specified in the table.
- ⇒ Montare il dispositivo di sblocco (5) regolando il gioco al valore indicato nella tabella relativa.
- ⇒ Before connecting the brake electrically, check the working rated voltage.

WARNING:

For direct current brakes with voltage input deriving from a half-wave current rectifier, remember that:

Rectifier input 400V CA output 178V DC

Rectifier input 230V CA output 103V DC

Insulated cable terminals of suitable section should be connected to the brake cables by means of crimping pliers.

Connect the brake power cables to the terminals + and - of the rectifier.

Assemble the bridge on the contact (see "Electric connections").

Connect the alternate current power cables to the terminals ~. If the brake must fulfill the EMC Directive requirements, use a NBRCE rectifier already fitted with the appropriate filter or connect in parallel a 0,22 μ f, 440 VAC, Class X1 condenser to the contacts ~.

SETTINGS

Always adjust the air-gap to the value specified on the drawing, by means of the self-locking nut on the shaft head.



MAINTENANCE

The periodical maintenance interval should be determined according to:

- ⇒ load to be braked and relative braking work;
- ⇒ braking work that can be carried out by the brake between two adjustment intervals;
- ⇒ braking work that can be carried out by the brake between two adjustment intervals.

Should the braking cycles and relative loads to be braked not be assumable in a safe way, avoid assembling the permanent hand release or establish very short maintenance intervals.

During maintenance:

- ⇒ check that the friction packing minimum thickness is not lower than 1 mm;
- ⇒ check the backlash between the fan hole (17) and the driving shaft (13).
- ⇒ check the absence of backlash between the key (14) and its housing on the hub
- ⇒ Replace the worn parts;
- ⇒ Adjust the air-gap, taking it back to its initial value by means of the nut (19).