

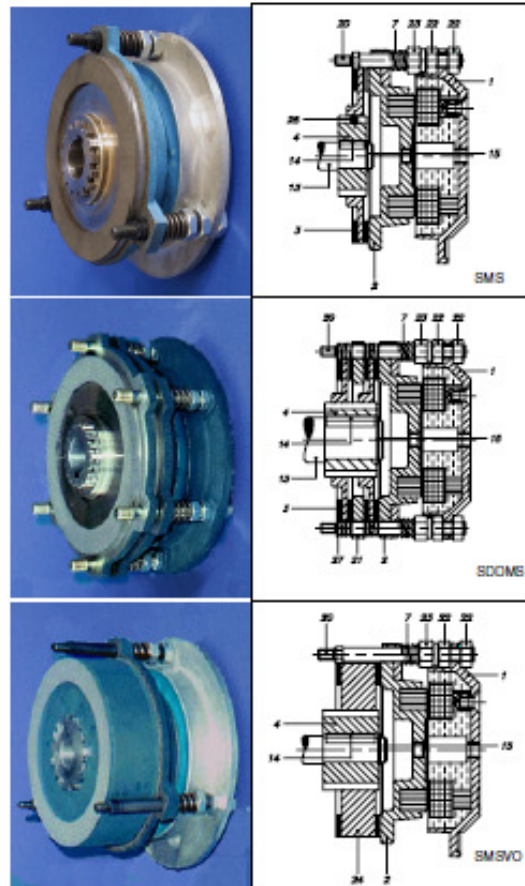

O.E.G. SPRING-PRESSURE SAFETY BRAKES IN THREE-PHASE ALTERNATE CURRENT, SINGLE-PHASE ALTERNATE CURRENT AND DIRECT CURRENT: SMS, SDDMS, SMSVO TYPE

INSTALLATION AND MAINTENANCE MANUAL

- 1 Magnet casing
- 2 Mobile anchor
- 3 Brake disc
- 4 Driving hub
- 5 Hand release lever (OPTIONAL)
- 6 Protection + "O" ring (OPTIONAL)
- 7 Thrust spring
- 8 "V" ring (OPTIONAL)
- 9 Guide pipe
- 10 Fastening screw
- 11 Locking nut
- 12 Braking torque adjusting screw (OPTIONAL)
- 13 Driving shaft
- 14 Key
- 15 Seeger ring
- 25 Antivibration 'O' ring (OPTIONAL)
- 26 Flange (OPTIONAL)

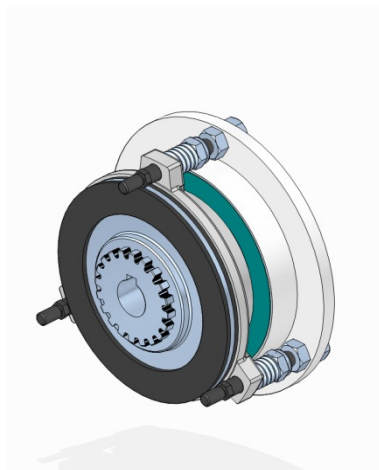
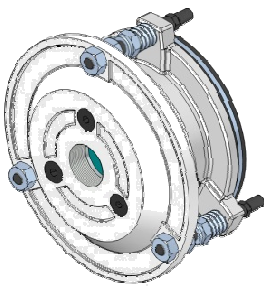



INSTALLATION

- ⇒ Make sure that the flange (26) receiving the brake is free from dirt, grease, etc., to prevent a reduction of the braking torque.
- ⇒ Make sure that the shaft projection (13) has the dimensions and tolerances specified in the drawings.
- ⇒ Assemble the driving hub (4) on the shaft fitted with the UNI 6604 tongue (14), shape B. Ensure the driving hub so that it cannot slide axially during operation of the machine.
- ⇒ Assemble the brake disc (3) with the antivibration 'O' ring (25), if required.
- ⇒ Tighten the screws (10) into the threaded holes on the flange.
- ⇒ Adjust the air-gap to the value specified in the table, by means of the lock nuts.
- ⇒ Assemble the release device (5), adjusting the backlash to the value specified in the relative table.
- ⇒ Assemble the rubber protections if required.
- ⇒ Before connecting the brake electrically, check the working rated voltage.
- ⇒ Connect the brake cable, taking care to choose the start and end of each phase (distinguished by two colors) to connect to the desired Δ or Y .

ELECTRICAL WARNINGS

For DC brakes with input voltage coming from a half-wave current rectifier, remember that:

Rectifier input 400 V AC Output 178 V DC

Rectifier input 230 V AC Output 103 V DC

Insulated cable terminals of suitable section should be connected to the brake cables by means of crimping pliers.

Connect to the ground cable - always yellow-green striped - an eyelet terminal with the dimensions of the hole on the terminal box. Secure the cable in the terminal box passage by means of a clamping screw for $\varnothing 6$ cables.



MAINTENANCE

The periodical maintenance interval should be determined according to:

- ⇒ load to be braked and therefore the braking work on.
- ⇒ working disposed between two of the brake adjustment intervals.
- ⇒ number of equivalent cycles (see the calculation graph in Chapter "Brake selection").

In the case where the cycles of the braking system and its loads to be braked were not conceivable securely, avoid assembling the permanent hand release or plan very short maintenance intervals.

During maintenance:

- ⇒ CHECK that the friction packing minimum thickness is not lower than 1 mm;
- ⇒ CHECK that the backlash between the brake disc (3) and the driving hub (4) is not excessive.
- ⇒ CHECK the absence of backlash between the key (14) and its housing on the hub
- ⇒ CHECK the absence of backlash between the driving hub (4) and the driving shaft (13).
- ⇒ REPLACE the worn parts
- ⇒ ADJUST the air-gap, taking it back to its initial value, by means of the screws (10) and lock it with the nuts (11).